

SAN 1600
Double stacker



Narrower than a EUR pallet

The SAN 1600 is a small, narrow and compact truck. It is even slimmer than the EUR pallet. Unlike conventional pedestrian stacker with a flip-down platform the driver stands protected inside the truck. Due to this the SAN 1600 also becomes significantly shorter. The truck can be equipped with hydraulic shock absorber and spring loaded castor wheels which provides incredible comfort and saves wear and tear when driving over joints.



Workplace Here you stand at a 45 degree riding position for optimum driving forward/backward. The steering wheel and driving unit is stepless adjustable and vibration isolated to reduce strain in the hands and arms.

Charging With a simple "pull" the charging glove folds out to the side of the truck and it is easily connected to the charger.

Protected The increased lumbar support provides excellent protection and support for the driver.

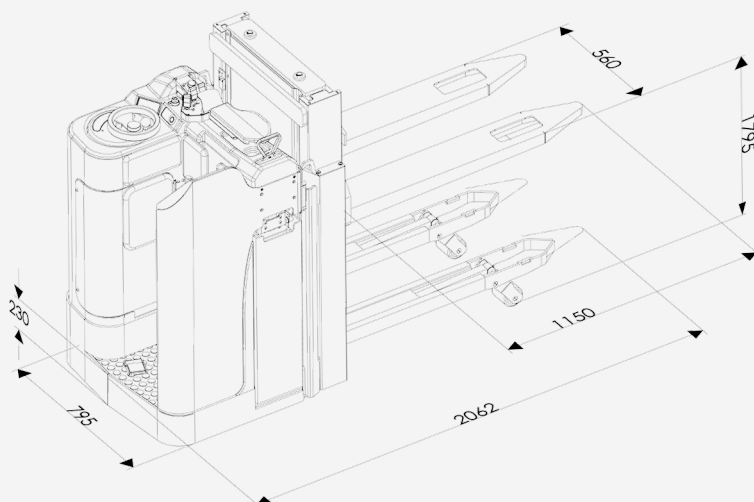

Safety

Speed reduce The driving speed drops continuously in turns

Pulsing brake Minimise the risk for the drive wheel locking or separating from the surface when braking

Lowering speed compensation Lowering Speed Compensation The truck's lowering speed is set automatically depending on the tonnage on the forks