



EXP20

2000kg Automatic Ride-On Pallet Truck



- **Simple Set up** – Enable automatic transportation with built-in navigation cameras, no reliance on WiFi or complex network setups.
- **Dual modes** — Easily switch between electric and automatic modes to adapt to diverse workflow demands.
- **Easy to use** — Simple, user-friendly operation that supports long-distance transport across factories, workshops, and large-scale facilities.
- **Designed for heavy-duty applications** – Delivers faster travel speeds and greater load capacity, offering an outstanding solution for high-efficiency applications.
- **Designed for repetitive tasks** – Perfectly suited for handling repetitive, simple material-moving workflows, reducing manual labor and human error.
- **Multi-task function** — Store up to 10 different routes, it delivers point-to-point navigation and automatic drop-off for streamlined workflows.



Manufacturer		EP
Model designation		EXP20
Drive		Electric
Load capacity	kg	2000
Service weight	kg	660
Load centre distance	mm	600
Dimensions (l1/b1/h1)	mm	2070/820/1695
Fork dimensions (s/e/l)	mm	55/170/1220
Lifting height	mm	110
Travel speed, laden/unladen	km/h	7.2/9
Turning radius	mm	1775
Battery voltage/nominal capacity	V/Ah	24/205
Safety protection		Lidar/Emergency stop button/Voice/Light
Positioning		Camera
Parking accuracy	mm	±20
Navigation accuracy	mm	±20

FEATURES

Simple deployment, WiFi-free automatic navigation

Automatic transportation via built-in navigation cameras — No WiFi or unstable network setup required — deployment is simpler and day-to-day operations stay straightforward.



Simple to use, keypad operation

User-friendly operation with no complex training required, set routes with a simple keypad, enabling automatic transport across factories, in production, and large warehouses.

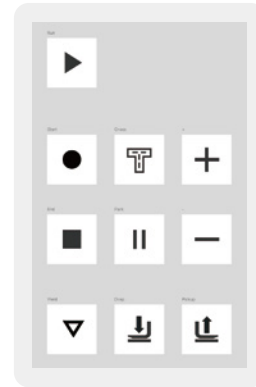

Dual modes, flexible switching

The optimized mast design ensures unobstructed visibility during manual operation — enhancing safety and precision — while supporting seamless switching between electric and automatic modes to adapt to diverse workflow demands.



Designed for heavy-duty applications, higher speed and heavier loads

Enhanced load capacity and travel speed, the EXP20 delivers robust heavy-duty performance: a rated load of 2000kg for demanding material transport, plus a full-load travel speed of 1.5 m/s to boost operational efficiency.

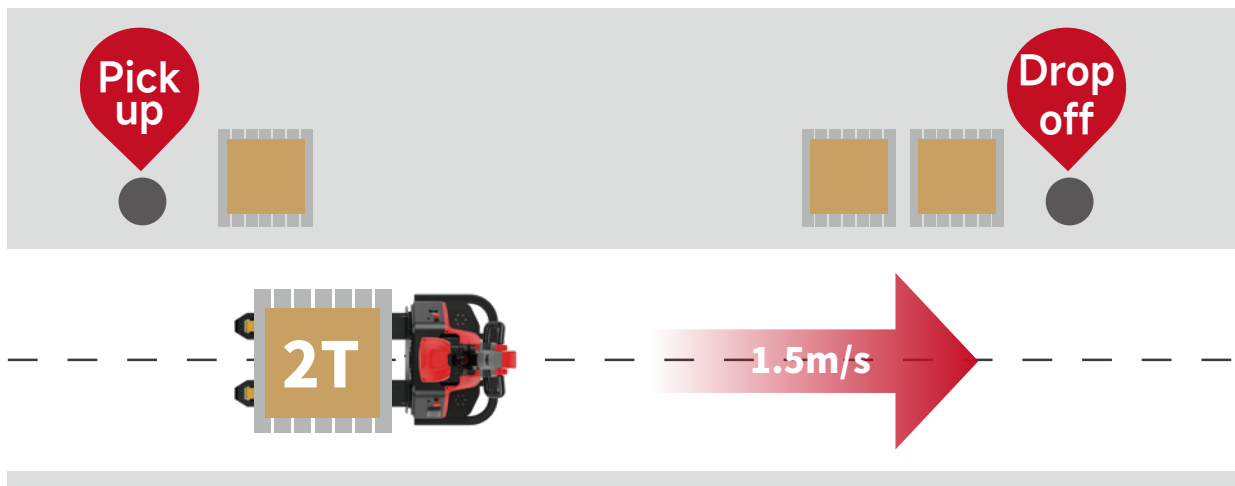

FEATURES

Designed for repetitive tasks, reducing manual labor needs

Switch from electric trucks to fully automatic trucks — significantly reducing physical labor. Save on manual labor expenses by up to 80%, all while keeping productivity high.



Multi-task function for great flexibility and adaptability

The EXP20 can handle multiple tasks, making it easier to adapt to different jobs. This improves transport efficiency and reduces the amount of manual effort needed. It can learn and save up to 10 routes, then drive point to point and drop off loads automatically to keep workflows smooth and simple.

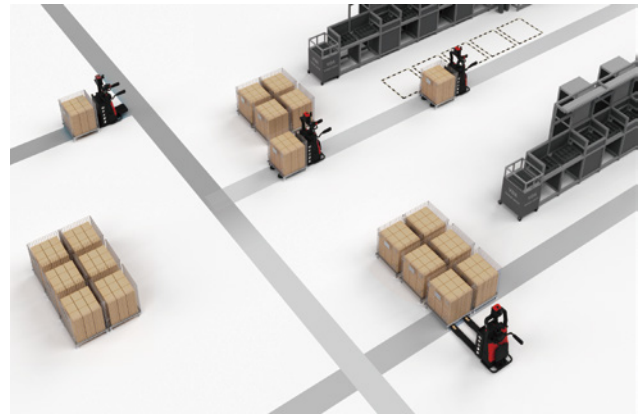

Core Application Scenarios

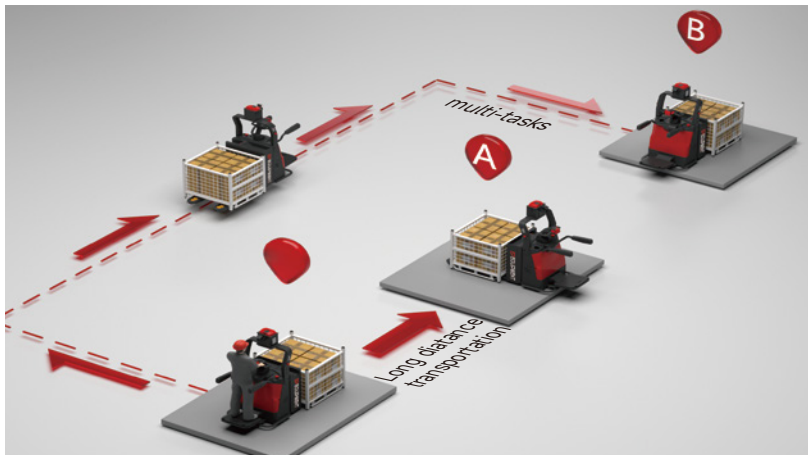

- Point-to-point transport (A-to-B)

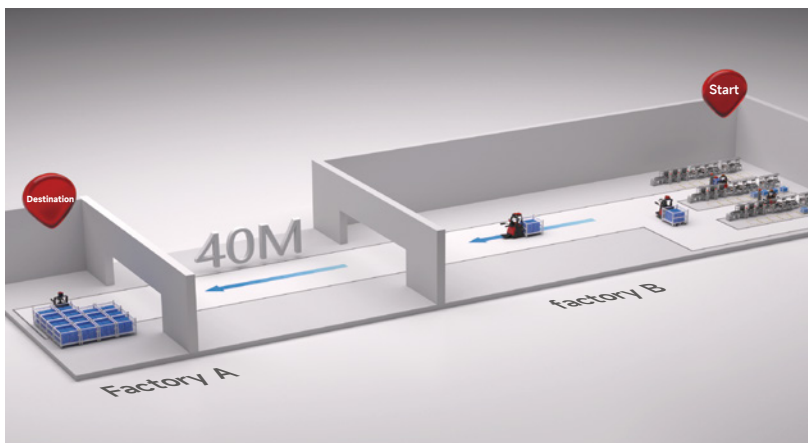

- Long-distance transport between buildings or factories

2000kg Automatic Ride-On Pallet Truck EXP20

Basic Parameters	1.1	Brand			EP
	1.2	Model			EXP20
	1.3	Operator type			Pedal
	1.4	Load capacity		kg	2000
	1.5	Service weight		kg	650
	1.6	Navigation	Q		Camera
	1.7	Positioning accuracy		mm	±20
Battery Parameter	2.1	Battery voltage/nominal capacity		V/Ah	24/205
	2.2	Battery type			Lithium battery
	2.3	Battery weight		kg	65
	2.4	Usage time		h	6~8
Size	3.1	Dimensions (l1/b1/h1)		mm	2000/820/1695
	3.2	Load centre distance	l1/b1/h1	mm	600
	3.3	Load length	c	mm	980
	3.4	Wheelbases	x	mm	1428
	3.5	Fork vertical length	y	mm	851
	3.6	Fork dimensions (s/e/l)	l2	mm	55/170/1220
	3.7	Outer width of forks	s/e/l	mm	600/685/540
	3.8	Height with forks lowered	b5	mm	90
	3.9	Lifting height	h13	mm	110
Other Parameters	4.1	Travel speed, laden/unladen	h3	km/h	9/10
	4.2	Lifting speed, loaded/unloaded		m/s	-
	4.30	Lowering speed, loaded/unloaded		m/s	-
	4.4	Max. gradeability, laden/unladen		%	8/16
	4.5	cross-ditch ability		mm	≤20
	4.6	turning radius		mm	1755
Channel Requirements	5.1	Straight forward/backward (with 1200mm*1000mm pallet) width	Wa	mm	1400
	5.2	Right-angle turn (with 1200mm*1000mm pallet) width	Ast	mm	2656
	5.3	Width of unilateral pick-up and unloading (with 1200mm*1000mm pallet)	Ast	mm	2956
Safety	6.1	Emergency stop button	Ast		two sides
	6.2	Voice and light			Voice/light
	6.3	Front protection			Top and bottom laser
	6.4	Rear protection			Fork Tip Optoelectronics
	6.5	Side protection			-
	6.6	Mechanical contact collision protection			Front bottom+ Side bottom
	6.7	Pallet in-place detection switch			Bumper Sensor

If there are improvements of technical parameters or configurations, no further notice will be given.
The diagram shown may contain non-standard configurations.

Product Line Diagram

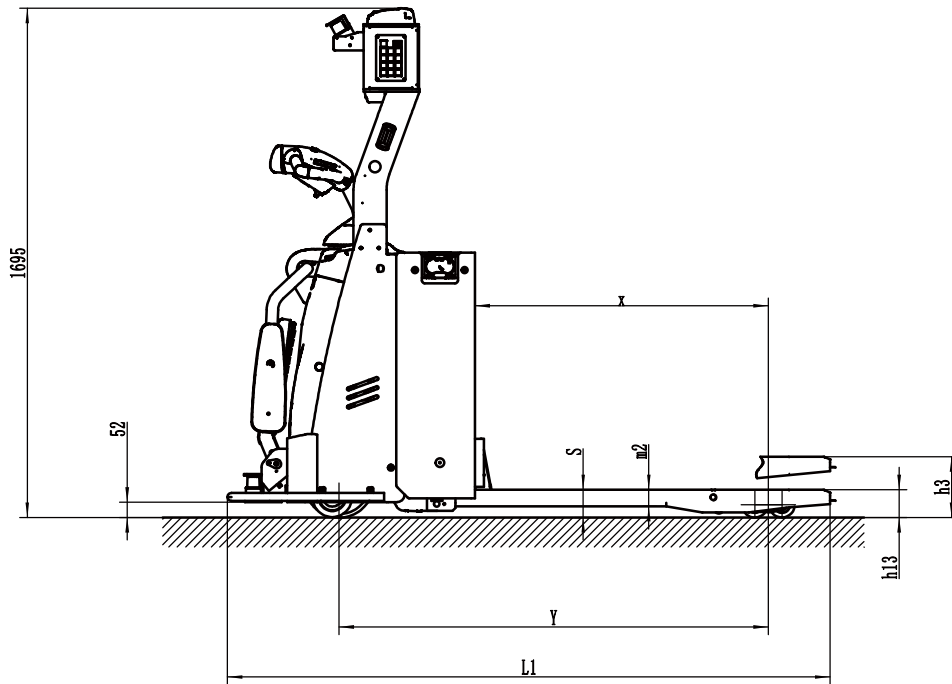

Side View

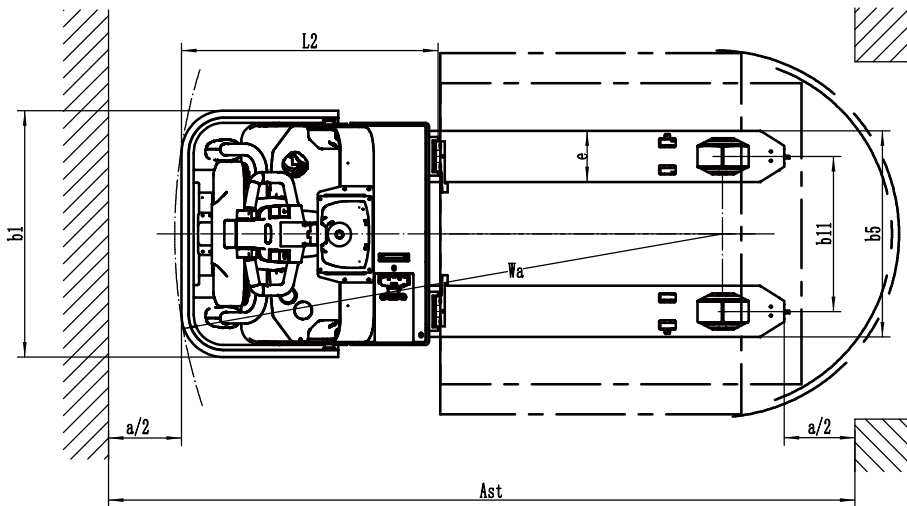

Top View